

INSTALLATION & OPERATION MANUAL FOR Cheesemelters

ITW Food Equipment Group

VULCAN

MODELS	MLS
VCM24	<i>ML-135124</i>
VCM34	<i>ML-135123</i>
VCM36	<i>ML-135126</i>
VCM48	<i>ML-135127</i>
VCM60	<i>ML-135128</i>
VCM72	<i>ML-135129</i>

www.vulcanhart.com



MODELS	MLS
CMJ24	<i>ML-135124</i>
CMJ34	<i>ML-135123</i>
CMJ36	<i>ML-135126</i>
CMJ48	<i>ML-135127</i>
CMJ60	<i>ML-135128</i>
CMJ72	<i>ML-135129</i>

www.wolfrange.com

IMPORTANT FOR YOUR SAFETY

THIS MANUAL HAS BEEN PREPARED FOR PERSONNEL QUALIFIED TO INSTALL GAS EQUIPMENT, WHO SHOULD PERFORM THE INITIAL FIELD START-UP AND ADJUSTMENTS OF THE EQUIPMENT COVERED BY THIS MANUAL.

POST IN A PROMINENT LOCATION THE INSTRUCTIONS TO BE FOLLOWED IN THE EVENT THE SMELL OF GAS IS DETECTED. THIS INFORMATION CAN BE OBTAINED FROM THE LOCAL GAS SUPPLIER.

IMPORTANT

IN THE EVENT A GAS ODOR IS DETECTED, SHUT DOWN UNITS AT MAIN SHUTOFF VALVE AND CONTACT THE LOCAL GAS COMPANY OR GAS SUPPLIER FOR SERVICE.

FOR YOUR SAFETY

DO NOT STORE OR USE GASOLINE OR OTHER FLAMMABLE VAPORS OR LIQUIDS IN THE VICINITY OF THIS OR ANY OTHER APPLIANCE.

WARNING: IMPROPER INSTALLATION, ADJUSTMENT, ALTERATION, SERVICE OR MAINTENANCE CAN CAUSE PROPERTY DAMAGE, INJURY OR DEATH. READ THE INSTALLATION, OPERATING AND MAINTENANCE INSTRUCTIONS THOROUGHLY BEFORE INSTALLING OR SERVICING THIS EQUIPMENT.

IN THE EVENT OF A POWER FAILURE, DO NOT ATTEMPT TO OPERATE THIS DEVICE.

INSTALLATION, OPERATION AND CARE OF CHEESEMELTERS

GENERAL

Cheesemelters are produced with quality workmanship and material. Proper installation, usage and maintenance of your Cheesemelter will result in many years of satisfactory performance.

Model	Number of Burners	BTU/hr Input Rating
VCM24, CMJ24	1	18,000
VCM34, CMJ34	1	24,000
VCM36, CMJ36	1	24,000
VCM48, CMJ48	2	18,000
VCM60, CMJ60	2	18,000 & 24,000
VCM72, CMJ72	2	24,000

INSTALLATION

Before installing, verify that the type of gas supply (natural or propane) agrees with the specifications on the rating plate located underneath the grease drip pan. If the supply and equipment requirements do not agree, do not proceed with the installation. Contact your dealer immediately.

UNPACKING

Immediately after unpacking, check for possible shipping damage. If the cheesemelter is found to be damaged, save the packaging material and contact the carrier within 15 days of delivery.

Before installing, verify that the type of gas (natural or propane) and the clearance dimensions (see page 4) agree with the specifications on the rating plate which is located under the crumb tray on the right side.

LOCATION

The equipment area must be kept free and clear of combustible substances.

	Minimum Clearances	
	Combustible Construction	Non-Combustible Construction
Back	2"	0"
Sides	20"	0
Bottom	10"	4"

The installation location must allow adequate clearances for servicing and proper operation. While another gas-fired cheesemelter can be placed adjacent to this Cheesemelter, there must be no obstruction to the front of the Cheesemelter. A minimum front clearance of 36" (91 cm) is required.

Do not obstruct the flow of combustion and ventilation air. Adequate clearance for air openings into the combustion chamber must be provided. Make sure there is an adequate supply of air in the room to replace air taken out by the ventilating system.

Do not permit fans to blow directly at the Cheesemelter. Avoid wall-type fans which create air cross currents within the room. Avoid open windows next to the Cheesemelter.

INSTALLATION CODES AND STANDARDS

The Cheesemelter must be installed in accordance with:

In the United States of America:

1. State and local codes.
2. National Fuel Gas Code, ANSI-Z223.1/NFPA #54 (latest edition). This shall include but not be limited to: NFPA #54 Section 10.3.5.2 for Venting. Copies may be obtained from The American Gas Association Accredited Standards Committee Z223, @ 400 N. Capital St. NW, Washington, DC 20001 or the Secretary Standards Council, NFPA, 1 Batterymarch Park Quincy, MA 02169-7471
3. NFPA Standard # 96 *Vapor Removal from Cooking Equipment*, latest edition, available from the National Fire Protection Association, Batterymarch Park, Quincy, MA 02269.

In Canada:

1. Local codes.
2. CAN/CSA-B149.1 Natural Gas Installation Code (latest edition).
3. CAN/CSA-B149.2 Propane Installation Code (latest edition), available from The Canadian Gas Association, 178 Rexdale Blvd., Etobicoke, Ontario, Canada M9W 1R3.

ASSEMBLY

Cheesemelters Mounted on a Counter (Fig. 1)

Cheesemelters mounted on a counter must be equipped with 4" (10 cm) legs. The countertop must be of noncombustible construction. Place Cheesemelter in position, then level. Unscrew the front legs from the chassis about $\frac{1}{4}$ " (6 mm) and remove the lower control panel for servicing.

Cheesemelters Mounted on a Wall (Fig. 2)

Secure brackets to the wall by means of lag screws or bolts. Make sure Cheesemelter is level and lag screws or bolts engage wall studs.

Cheesemelter Mounted on Special Hi-Shelf (Fig. 3)

If the Cheesemelter is to be mounted over a Gas Range, a reinforced hi-shelf and special mounting brackets are required. These are furnished when ordered as an elevated Cheesemelter.

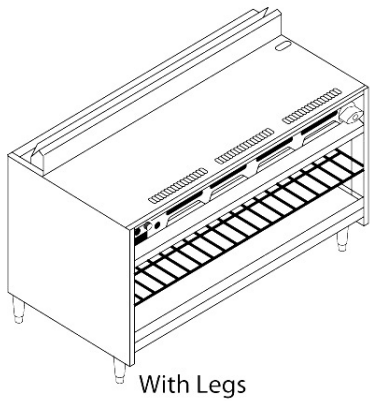

PL-53627

Fig. 1

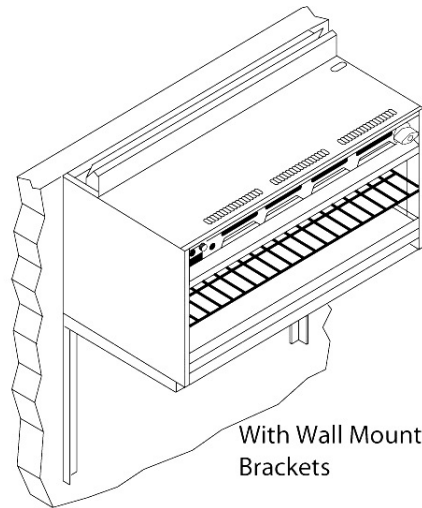

Fig. 2

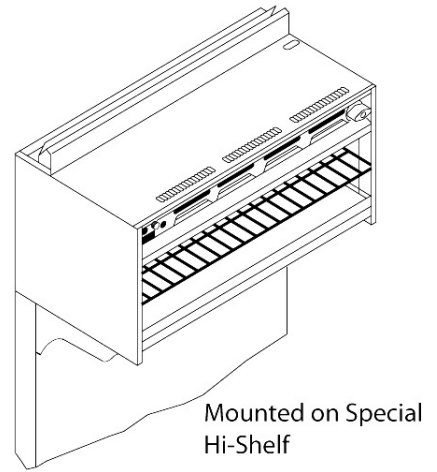

Fig. 3

1. Remove existing rear shelf and install the reinforced high shelf.
2. Install mounting brackets on both top corners of reinforced shelf, using the four bolts provided.
3. Place and align Cheesemelter on top of brackets; place the back of the unit flush with the rear of the shelf.
4. Using a #19 drill bit, drill from below through the four holes provided on the mounting bracket into the base of the unit.
5. Drive four #10-24 self-tapping screws (provided) into the drilled holes.
6. Attach both Cheesemelter and high shelf to the common rear panel with self-tapping screws.

GAS CONNECTIONS

CAUTION: Gas supply connections and any pipe joint compound must be resistant to the action of propane gases.

Location of the gas inlet is at the top right rear corner of the top panel. Codes require that a gas shutoff valve must be installed in the gas line ahead of the Cheesemelter.

Connect gas supply (1/2" pipe minimum recommended size). Make sure the pipes are clean and free of obstructions.

NATURAL GAS: Standard orifices are set at 6" W.C. A pressure regulator is supplied and must be installed when appliance is connected to gas supply.

PROPANE GAS: Standard orifices are set at 10" W.C. A pressure regulator is supplied and must be installed when cheesemelter is connected to gas supply.

Maximum line pressure for natural and propane gas is 14" W.C. Minimum line pressure is 7" W.C. for natural gas and 11" W.C. for propane gas.

GAS PRESSURE REGULATOR INSTALLATION

Gas regulator pressure is preset at 5" Water Column (W.C.) for natural gas, and 10" W.C. for propane gas. No further adjustment should be required.

Install the regulator as close to the cheesemelter on the gas supply line as possible. Make sure that the arrow on the underside of the regulator is oriented in the direction of gas flow to the cheesemelter (Fig. 2) and the regulator is positioned with the vent plug and adjustment screw upright (Fig. 3).

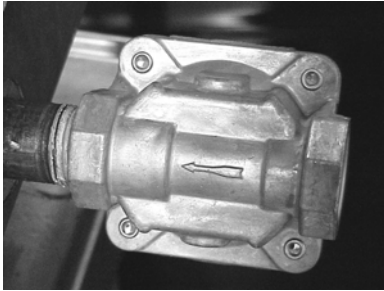

Fig. 2

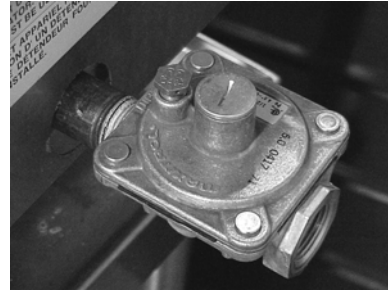

Fig. 3

The supply pressure (upstream of the regulator) should be 7-9" W.C. for natural gas and 11-12" W.C. for propane gas. At no time should the cheesemelter be connected to supply pressure greater than ½ psig (3.45 kPa) or 14" W.C.

TESTING THE GAS SUPPLY SYSTEM

When gas supply pressure exceeds ½ psig (3.45 kPa), the Cheesemelter and its individual shutoff valve must be disconnected from the gas supply piping system.

When gas supply pressure is ½ psig (3.45 kPa) or less, the Cheesemelter should be isolated from the gas supply system by closing its individual manual shutoff valve.

FLUE CONNECTIONS

DO NOT obstruct flow of flue gases from the flue located on the rear of the Cheesemelter. It is recommended that the flue gases be ventilated to the outside of the building through a ventilation system installed by qualified personnel.

Information on the construction and installation of ventilating hoods may be obtained from the standard for "Vapor Removal from Cooking Equipment," NFPA No. 96 (latest edition), available from The National Fire Protection Association, Batterymarch Park, Quincy, MA 02269.

OPERATION

WARNING: THE CHEESEMELTER AND ITS PARTS ARE HOT. BE CAREFUL WHEN OPERATING, CLEANING OR SERVICING THE CHEESEMELTER.

CONTROLS

Burner Valve — the burner valve regulates the flow of gas throughout the Cheesemelter. Gas flow is increased by turning the valve counterclockwise. After preheating, the maximum output is not required. Turn the valve clockwise until the desired performance is achieved.

Sliding Shelves (Rack) — there are three rack positions. Place the shelf on the rack needed for Cheesemelting. For deeper, longer heat, use lower positions. For thinner foods, or faster cooking, use top shelves.

Grease Pan (Drip Tray) — the grease pan collects grease and waste. Do not allow the grease pan to overflow. Empty the grease pan when three-quarters full to reduce the possibility of spillage.

Pilot Adjustment Valve — regulates the flow of gas to the pilot burner.

LIGHTING, RELIGHTING AND SHUTDOWN INSTRUCTIONS

1. Turn gas shutoff valve and burner valve to the OFF position and wait 5 minutes.
2. Turn gas shutoff valve ON. Light the pilot adjacent to the main burner. Adjust the pilot valve screw until the pilot flame has a slight yellow tip.
3. After the pilot has been established, turn the burner valve to the ON position. The burner flames may be adjusted, using the air shutters located behind the louvered panel in the front of the broiler below the burner valve.
4. If the burners fail to light, turn off all valves, wait 5 minutes and repeat steps 1-3.
5. To shut down, turn the burner valves to the OFF position.

PREHEATING

Place the rack in its highest position. Turn the burner valve knob completely counterclockwise and preheat for 15 minutes.

RECIPE AND RACK ADJUSTMENT

Positioning the Cheesemelter rack is an important factor in the desired product end results. Position the rack farther away from the burners for thick casseroles and for melting cheese or butter to avoid drying the product. Position the rack closer to the burners for bacon, toast and quick heating, but watch carefully to avoid burning.

LOADING AND UNLOADING

Place the rack in the desired position. Pull the rack out for loading. Load as quickly as possible and avoid spillage. Push the rack into place and cook for the appropriate time. Lower and pull the rack out for unloading.

CLEANING

Interior

When the Cheesemelter is cool, remove rack. Clean the rack and drip tray daily by soaking in warm detergent water. Scrub with a stiff-bristled brush. Do not use harsh abrasives.

After scrubbing, wash with soapy water, rinse and dry. Soap and water will normally do the job. Heavy spattering or spillovers may require cleaning with mild cleaner or soapy wet pads.

Exterior

When the Cheesemelter is cool, knobs and stainless steel surfaces may be cleaned with mild soap and water applied with a damp cloth. Rinse the surface with clean water and dry with a soft clean cloth. Do not use abrasive cleaners or strong liquid cleaners on stainless steel surfaces as they may damage the finish.

Spray-On Cleaners

Be careful when using spray-on cleaners. Some cleaners may contain caustics. Please follow cleaner manufacturer's instructions.

MAINTENANCE

WARNING: THE CHEESEMELTER AND ITS PARTS ARE HOT. BE CAREFUL WHEN OPERATING, CLEANING OR SERVICING THE CHEESEMELTER.

LUBRICATION

All moving parts must be checked for wear and lubricated if necessary. Contact your local Service Agency.

All valves and controls should be lubricated with a high-temperature grease by your local Service Agency.

VENT

Annually, when the Cheesemelter is cool, check the flue and clear any obstructions.

SERVICE AND PARTS INFORMATION

Contact the Service Agency in your area to obtain service and parts information.

TROUBLESHOOTING

PROBLEM	POSSIBLE CAUSES
Uneven heating Side burning	<ol style="list-style-type: none"> 1. Temperature too low 2. Improper operation of Cheesemelter 3. Fluctuating gas pressure
Too much top heat	<ol style="list-style-type: none"> 1. Temperature too high 2. Improper ventilation 3. Excessive heat input 4. Pressure too high, or orifice(s) too large
Uneven heat, side to side	<ol style="list-style-type: none"> 1. Cheesemelter not level, side to side 2. Cheesemelter burner improperly installed
Uneven heat, front to back	Cheesemelter not level, front to back
Dried-out products	<ol style="list-style-type: none"> 1. Melting time too long, or product too close to burners 2. Pressure too high, or orifice(s) too large
Pilot outage	<ol style="list-style-type: none"> 1. Pilot flame too low 2. Restriction in pilot orifice
Poor ignition	<ol style="list-style-type: none"> 1. Insufficient gas input 2. Poor air-to-gas adjustment 3. Restriction in pilot orifice 4. Restriction in main burner ignition port 5. Pilot adjustment is incorrect